

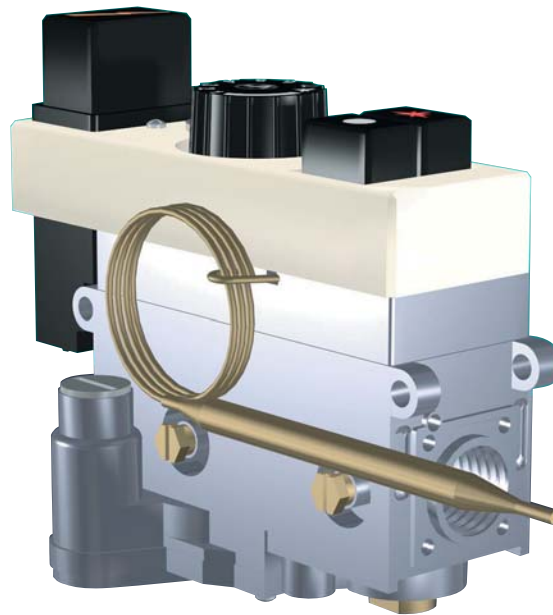

SITGroup

710 MINISIT



MULTIFUNCTIONAL GAS CONTROL

Application

The 710 MINISIT is suitable for use with stoves, boilers, catering equipment and room heaters.

Main features

Thermoelectric flame supervision device.
Pressure regulator.
Temperature control.

Normative Reference

EN 126
Multifunctional devices for gas burning appliances.



VALVE DESCRIPTION

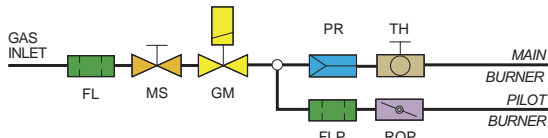

Fig. 1: version with pressure regulator.

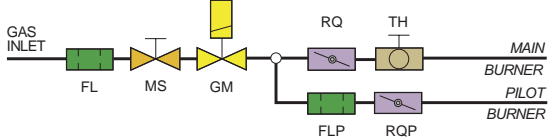

Fig. 2: version with flow adjuster.

710 MINISIT is a multi-functional control incorporating thermoelectric flame supervision device with restart interlock, pressure regulator or flow adjuster, modulating thermostat with snap acting on-off function.

With reference to the schematic blocks in Fig. 1 and Fig. 2:

- FL is the inlet filter.
- MS is the operation push button.
- GM is the thermoelectric flame supervision device.
- FLP is the pilot filter.

- RQP is the pilot flow adjuster.
- PR is the pressure regulator.
- RQ is the main gas flow adjuster.
- TH is the modulating thermostat with on/off function with temperature selecting knob.

- 1 Ignition button
- 2 Shut-down button
- 3 Piezo-electric ignition button (optional)
- 4 Temperature setting knob
- 5 Pilot flow setting screw
- 6 Minimum flow setting screw
- 7 Maximum flow setting screw (versions with flow adjuster)
- 8 Outlet pressure setting screw (versions with pressure regulator)

- 9 Inlet pressure test point
- 10 Outlet pressure test point
- 11 Thermocouple connection
- 12 Pilot outlet
- 13 Gas inlet
- 14 Main gas outlet
- 15 Bottom gas outlet
- 16 Flange fixing holes
- 17 Mounting holes
- 18 Thermostat bulb

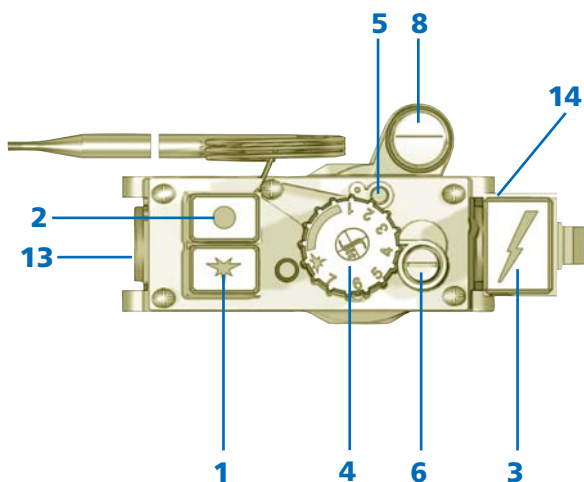

Fig. 3: version with pressure regulator and piezo-electric igniter.

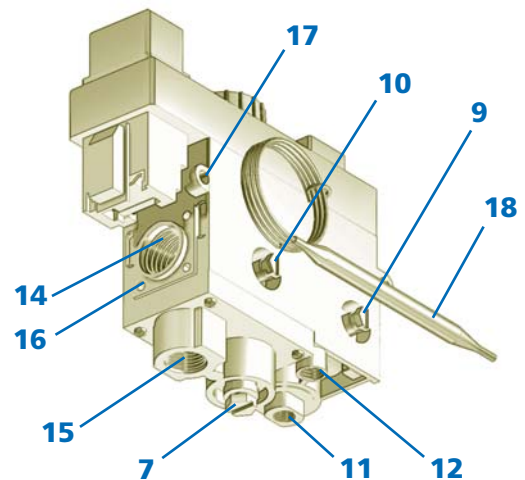

Fig. 4: version with flow adjuster and piezo-electric igniter.

GENERAL DATA

CONSTRUCTION CHARACTERISTICS

- Aluminium alloy body
- Inline inlet and outlet (straight and elbow flange available)
- Bottom outlet (optional)
- Pilot gas rate adjuster
- Pressure regulator or as an alternative flow adjuster
- Inlet and outlet pressure test points (optional)
- Inlet and pilot filters
- Piezo-electric igniter (optional)
- Four mounting holes

USE SPECIFICATIONS

- Mounting position any
- Gas families I, II and III
- Ambient temperature 0...80 °C
- Maximum inlet pressure 50 mbar
- Bending and torsion resistance Group 2

MECHANICAL CONNECTIONS

- Gas inlet and outlet Rp 1/2 or Rp 3/8 ISO 7
- Pilot outlet M10x1 for tube $\varnothing 6$, $\varnothing 4$ mm, $\varnothing 1/4$
- Thermocouple connection M9x1 or M10x1
- Pressure test point $\varnothing 9$ mm
- Flange fixing holes M4 x 7 mm
- Mounting holes $\varnothing 6.5$ mm

FUNCTIONS

FLAME SUPERVISION

- Number of cycles expected 5.000
- Ignition time (*) < 10 s
- Shut-off time (*) < 60 s

(*) using SIT series 200 or 290 thermocouple.

PRESSURE REGULATION

- Direct pressure regulator Class B
- Outlet pressure setting range (optional) 3...18 mbar (15...30 mbar)
- Built-in cutout device to exclude the pressure regulator (if necessary)



THERMOSTAT DATA

A - B	a	b	c
8 - 33	3	3	2
13 - 31	2	2	2
13 - 38	3	3	2
13 - 48	4	4	3
21 - 46	3	3	2
30 - 100	9	9	5
40 - 72	5	5	3
40 - 80	5	5	3
100 - 340	30	30	10

All the values are expressed in °C

Other ranges are available on request

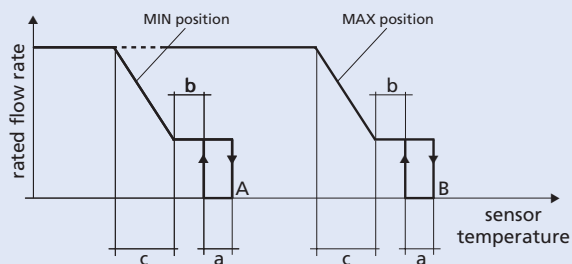

Data refer EN 126 standard:

a: temperature differential

b: foot

c: modulating band

CAPACITY

FLOW RATE Q AS A FUNCTION OF PRESSURE DROP ΔP

Gas family	Q	ΔP
I d=0.45	3.9 m ³ /h	5 mbar
II d=0.6	3.5 m ³ /h	5 mbar
III d=1.7	4.4 m ³ /h	5 mbar

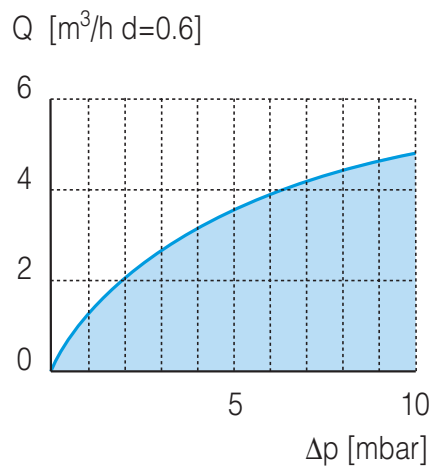

REGULATED FLOW RATE Q

Inlet pressure range (mbar)

Gas family	Nominal	Maximum	Minimum
2H	20	25	17
2L	25	30	20

Outlet pressure tolerance +10% -15%

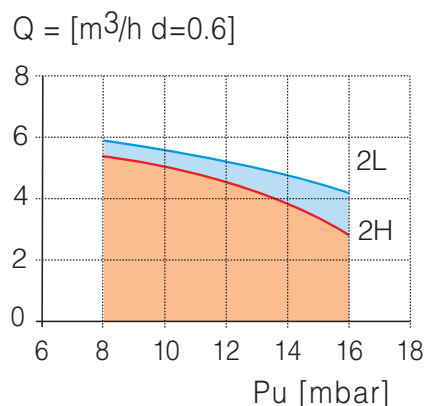

FUNCTIONAL DESCRIPTION

710 MINISIT has a magnet unit safety valve and a modulating valve in series. When the ignition button is pressed, the main flow valve closes the gas flow and the magnet unit opens the pilot gas flow. The thermocouple, heated by the pilot flame, generates sufficient current within a few seconds to keep the magnet unit energized.

The main gas flow is opened when ignition button is released. With the temperature setting knob it is possible to set the desired temperature. The thermostat bulb controls the main gas flow by means of the snapping valve and the modulating valve of the thermostat. These adjust gas flow to the main burner so as to maintain the desired ambient temperature.

It is possible to measure the inlet pressure and the outlet pressure on the respective pressure test points.

The pressure regulator due to a single diaphragm system allows improved performance of outlet pressure regulation. The outlet pressure can be adjusted by a screw.

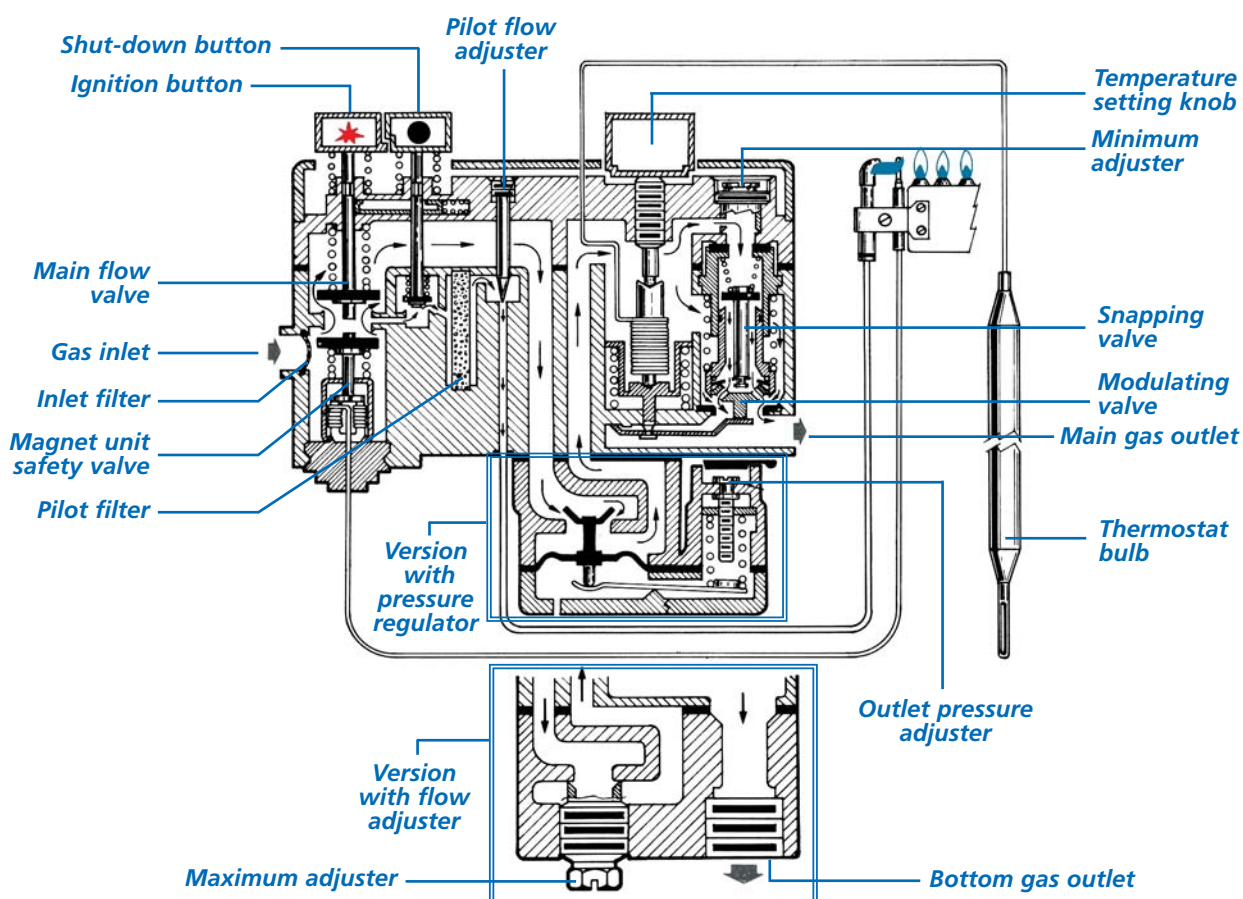



OPERATION



Fig. 5



Fig. 6



Fig. 7

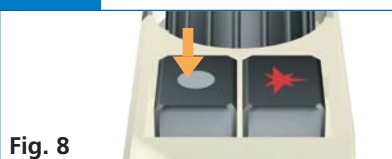



Fig. 8

Ignition

Press button  and keep it depressed (Fig. 5).

Light the pilot burner and wait a few seconds. If the valve is fitted with a piezo-electric igniter, press button  to light the pilot burner (Fig. 6). Release button  and check that the pilot flame stays on, otherwise repeat the ignition procedure.

Normal operation

Set knob to the temperature required.

The maximum temperature setting is obtained by turning the knob fully anti-clockwise (Fig. 7).

Pilot position

Turn knob fully clockwise.

Shut-down

Press button  right down (Fig. 8).

CAUTION: The re-start interlock device prevents the appliance from re-igniting until the flame supervision device has interrupted the gas flow. After this stage (i.e. when the magnet unit has closed) it is possible to re-ignite the appliance.

SETTINGS AND ADJUSTMENTS

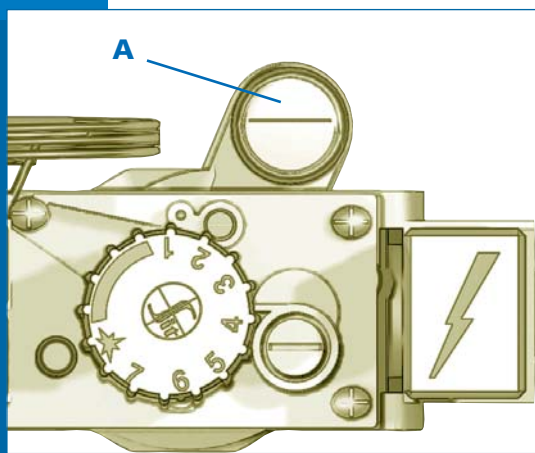

Adjusting the outlet pressure

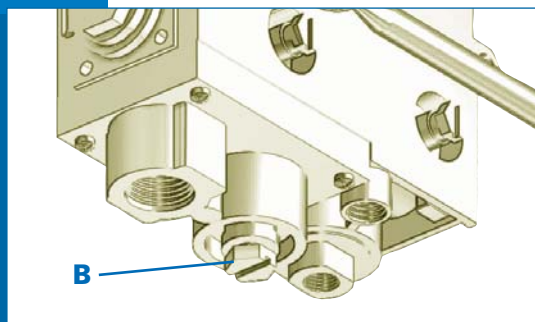

Adjusting the outlet flow

Setting the thermostat

The thermostat is calibrated and sealed at the factory.

Re-calibration is not authorised as it may adversely affect the performance of the appliance to which it is fitted and will also invalidate warranty.

Low fire adjustment

Turn the MIN screw clockwise to decrease the flow, anti-clockwise to increase it (calibrated screws available on request).

Adjusting pilot gas flow

Turn the relevant screw clockwise to decrease the flow or anticlockwise to increase it.

Adjusting the outlet pressure

(Versions with pressure regulator)

Remove the cap and turn the setting screw (A) clockwise to increase the outlet pressure or anticlockwise to reduce it.

Adjusting the outlet flow

(Versions with pressure regulator)

Remove the safety cap.

Turn the screw (B) clockwise to decrease the flow or anticlockwise to increase it.

Putting pressure regulator out of function

For MINISIT operation on third family gases ensure:

- The MIN screw is replaced by a pre-drilled version MIN screw as specified by the appliance manufacturer. This screw must be screwed fully home.
- The pilot adjusting screw is un-screwed two turns from the fully closed position.
- Pressure regulator adjustment screw is screwed fully clockwise or if an output flow adjuster is fitted, it is screwed fully anticlockwise, so that they are non-operable thereby enabling the gas supply regulator to be ineffective.

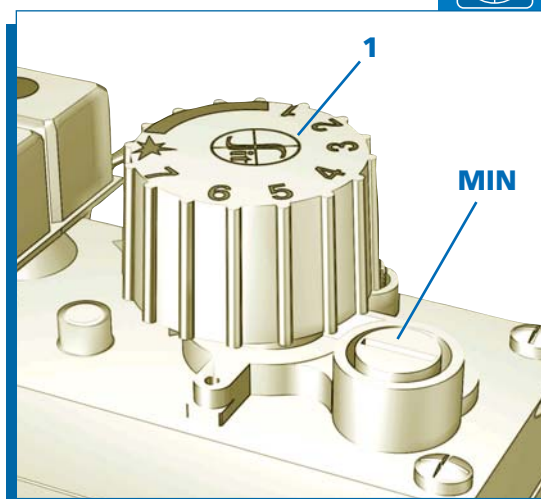

Low fire adjustment

All the detailed guidelines for installation are given in the use and installation instructions code 9.956.710.

DIMENSIONAL DRAWING

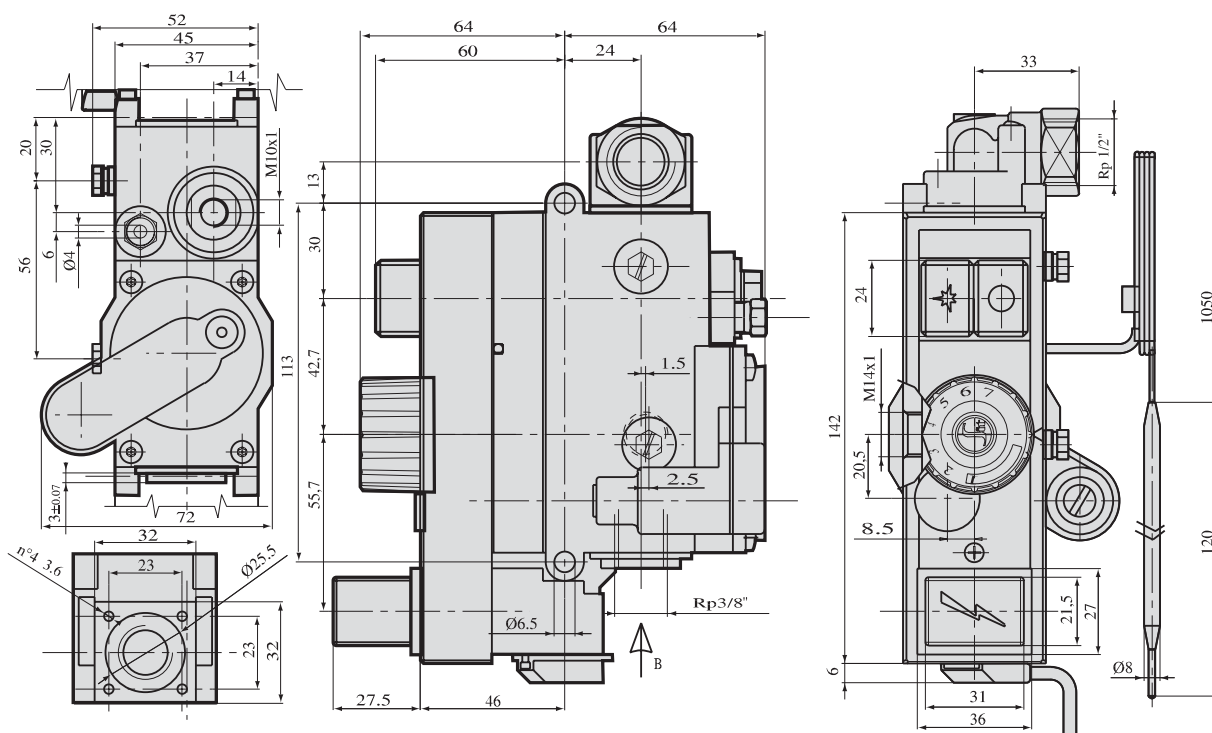

NOTE: All the dimensions are expressed in millimeters.



SITGroup

SIT La Precisa S.p.A.

Viale dell'Industria 31-33

35129 PADOVA - ITALY

Tel. +39/049.829.31.11, Fax +39/049.807.00.93

www.sitgroup.it - e-mail: mkt@sitgroup.it
